

Planer knives.....	284-291
Turn over knives.....	292-306
Blancs with back tothing.....	307-314

Planer knives 30 x 3

Quality HS 18%, HW tipped

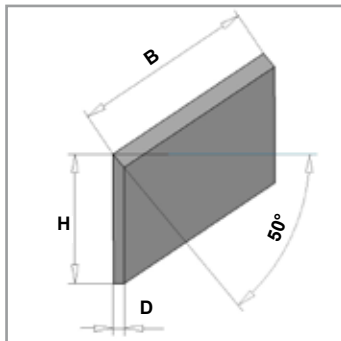

61030

APPLICATION:

HS 18% = For soft and hard wood

HW tipped = For hard wood, laminated wood and panel material

DESIGN:

Ground ready for use

Packing unit 2 pcs.

Width mm	Height mm	Thick-ness mm	DT	Order No. HS 18%	Order No. HW
80	30	3	◇	10013223	10013895
120	30	3	◇	10013480	10007302
130	30	3	◇	40015586	40015651
150	30	3	◇	10007285	10009176
180	30	3	◇	40015587	10013901
190	30	3	◇	40012338	10100358
210	30	3	◇	40000391	10007309
230	30	3	◇	10007289	10007310
250	30	3	◇	10022254	10007312
260	30	3	◇	10021671	10017859
270	30	3	◇	10106511	10110494
300	30	3	◇	10009356	10007313
310	30	3	◇	10009314	10009218
350	30	3	◇	10023659	10007315
400	30	3	◇	10013387	10007317
410	30	3	◇	10009322	10007319
450	30	3	◇	40000404	10007321
500	30	3	◇	10028612	10041808
510	30	3	◇	10024704	10007324
520	30	3	◇	10020417	10041809
530	30	3	◇	40000407	10009411
610	30	3	◇	10013161	10024127
630	30	3	◇	10024703	40003161
640	30	3	◇	10009380	10007329
710	30	3	◇	40009499	10017858
810	30	3	◇	10022779	10007331

Planer knives 35x3

Quality HS 18%, HW tipped

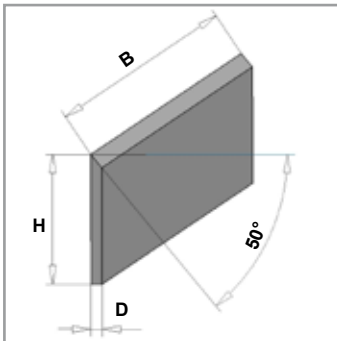
**61030**

APPLICATION:

HS 18% = For soft wood and hard wood

HW tipped = For hard wood, laminated wood and panel material

DESIGN:

Ground ready for use

Packing unit 2 pcs.

Width mm	Height mm	Thick-ness mm	DT	Order No. HS 18%	Order No. HW
250	35	3	◇	10009292	10009196
260	35	3	◇	40000592	10041812
270	35	3	◇	10106280	10110496
300	35	3	◇	10029021	10041813
310	35	3	◇	10022846	10026495
350	35	3	◇	10009319	10009223
400	35	3	◇	10024662	10007318
410	35	3	◇	40015284	10009227
450	35	3	◇	10104872	10007322
500	35	3	◇	10026359	10030833
510	35	3	◇	10013104	10007325
520	35	3	◇	10020335	10041815
530	35	3	◇	10030684	10041816
610	35	3	◇	10031855	10007327
630	35	3	◇	40000604	10027187
640	35	3	◇	10007298	40002376
710	35	3	◇	10101966	10041817
810	35	3	◇	10021924	10007332

SAWBLADES

HOGGERS

CUTTER WITH BORE

SHANK TYPE CUTTERS

DRILLS

KNIVES

CLAMPING SYSTEM

DP - TOOLS

ACCESSORIES

Knives for system Brück HL and Cobalt Quality

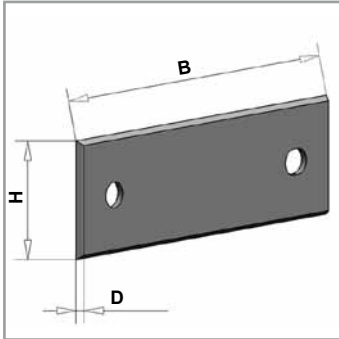

60070

APPLICATION:

HL = For soft wood
Cobalt = For soft wood and hard wood

DESIGN:

Ground ready for use
Disposable TOK = cannot be resharpened

Packing unit 20 pcs up to B=260 mm,
Packing unit 12 pcs from B=300 mm.

Width mm	Height mm	Thick-ness mm	DT	Order No. HL	Order No. cobalt
60	18,6	1	◇	10108727	10108729
80	18,6	1	◇	40012815	40002502
100	18,6	1	◇	40000634	40015677
105	18,6	1	◇	10102172	10102173
110	18,6	1	◇	10102176	10102175
120	18,6	1	◇	10025696	10102178
130	18,6	1	◇	10102026	40009494
136	18,6	1	◇	40009498	10102182
150	18,6	1	◇	40008623	10031019
170	18,6	1	◇	10102185	10102186
180	18,6	1	◇	40003509	10031397
186	18,6	1	◇	10102189	10102190
190	18,6	1	◇	10014486	10102192
210	18,6	1	◇	10014921	10102194
230	18,6	1	◇	40000637	40015079
240	18,6	1	◇	10102197	10102198
250	18,6	1	◇	10102200	10102201
260	18,6	1	◇	10014484	10029512
300	18,6	1	◇	40010793	10102203
305	18,6	1	◇	10102204	10102205
310	18,6	1	◇	10042387	10102207
320	18,6	1	◇	10100830	10102209
350	18,6	1	◇	10102210	10102211
360	18,6	1	◇	10102212	10102213
400	18,6	1	◇	40006550	10102214
410	18,6	1	◇	10018695	10102215
420	18,6	1	◇	10102216	10102217
450	18,6	1	◇	10015981	10102218
460	18,6	1	◇	10100975	10102220
500	18,6	1	◇	10102221	40005962
510	18,6	1	◇	10101684	40014627
520	18,6	1	◇	10102223	10102224
530	18,6	1	◇	10015980	10102225
600	18,6	1	◇	10102226	10102227
610	18,6	1	◇	10023744	10102228
630	18,6	1	◇	10101682	10102229
640	18,6	1	◇	40005413	10102230
660	18,6	1	◇	10102232	10102233
710	18,6	1	◇	10102234	10102235
810	18,6	1	◇	10102236	10102237

Knives for system Brück

HL Quality

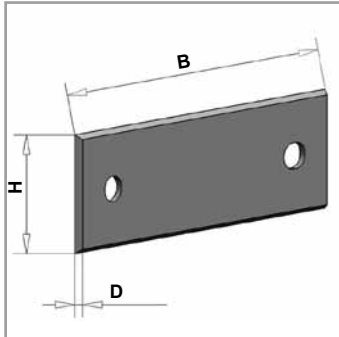

60070

APPLICATION:

For soft wood

DESIGN:

Ground ready for use. Disposable TOK = cannot be resharpened
 Packing unit 20 pcs up to B=260 mm,
 Packing unit 12 pcs from B=300 mm

Width mm	Height mm	Thickness mm	Machine	DT	Order No.
205	18,6	1	HolzHer, Hema	◇	40006562
280	18,6	1	Mafell	◇	40000639
300	18,6	1	HolzHer, Hema	◇	40000641
300	18,6	1	Mafell	◇	40000640
320	18,6	1	Mafell	◇	40008827
350	18,6	1	HolzHer, Hema	◇	40009406

SAWBLADES

HOGGERS

CUTTER WITH BORE

SHANK TYPE CUTTERS

S

DRILLS

KNIVES

CLAMPING SYSTEM

C

DP - TOOLS

ACCESSORIES

Knives for system Centrofix Quality HS 18%

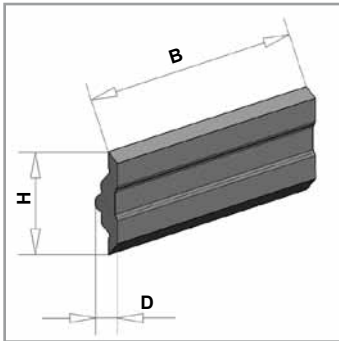

60030

APPLICATION:

HS 18 % = For soft wood and hard wood

DESIGN:

Ground ready for use
Disposable TOK = cannot be resharpened

Packing unit 2 pcs.

Available also in HW

Width mm	Height mm	Thickness mm	DT	Order No.
50	12	2,7	◇	10042188
60	12	2,7	◇	10017434
80	12	2,7	◇	10042265
100	12	2,7	◇	40003708
120	12	2,7	◇	10042270
130	12	2,7	◇	10031777
136	12	2,7	◇	10042273
150	12	2,7	◇	10042274
180	12	2,7	◇	40010794
190	12	2,7	◇	10042276
210	12	2,7	◇	10042277
230	12	2,7	◇	10101712
240	12	2,7	◇	40006645
310	12	2,7	◇	10013238
400	12	2,7	◇	10024764
410	12	2,7	◇	40006200
420	12	2,7	◇	10024497
430	12	2,7	◇	10018410
500	12	2,7	◇	10103127
510	12	2,7	◇	10019888
520	12	2,7	◇	40007794
530	12	2,7	◇	40005756
540	12	2,7	◇	10100478
600	12	2,7	◇	40012730
610	12	2,7	◇	10100479
630	12	2,7	◇	10018811
640	12	2,7	◇	10042179
810	12	2,7	◇	10100480

S AWBLADES
H OGGERSS
C UTTER WITH BORE
C HANK TYPE CUTTERS
S
D RILLS
K NIVES
C LAMPING SYSTEM
DP - TOOLS
A CCESSORIES

Knives for system Centrolock / Weinig

Quality HS 18 %, HW and HS M 42

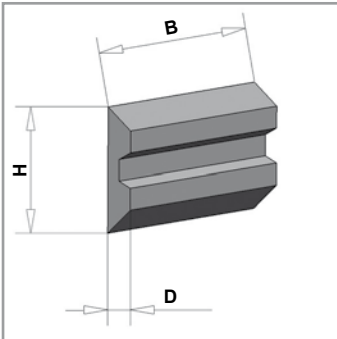

60030/ 60070

APPLICATION:

HS 18 % = For soft wood and hard wood

HW = For hard wood, laminated wood and panel material.

HS M42 = For soft wood

DESIGN:

Ground ready for use

TOK = can be resharpened

Packing unit 2 pcs.

Width mm	Height mm	Thickness mm	DT	Order No. HS 18%	Order No. HW	Order No. HS M42
20	16	3	◇	10100634	10101141	10153516
60	16	3	◇	10100637	10101142	10153517
80	16	3	◇	10100639	10041559	10153518
100	16	3	◇	40011198	10101143	10153519
130	16	3	◇	40002379	40015446	10153520
150	16	3	◇	10100641	10041560	10153521
170	16	3	◇	10031241	10031688	10153522
180	16	3	◇	10100642	10101144	10153523
190	16	3	◇	10100643	10020595	10153524
210	16	3	◇	10101132	10101187	10153525
230	16	3	◇	10025405	10017355	10153526
240	16	3	◇	10101709	40015447	10153527
260	16	3	◇	10101134	10101188	10153528
270	16	3	◇	10101136	40016138	10153529
310	16	3	◇	10101139	10101189	10153530
460	16	3	◇	10101140	10101190	10153531

NEW

S
AWBLADES

H
LOGGERS

C
UTTER WITH BORE

S
HANK TYPE CUTTERS

D
RILLS

K
NIVES

C
LAMPING SYSTEM

DP - TOOLS

A
CCESSORIES

Knives for system Terminus

Quality HS 18%

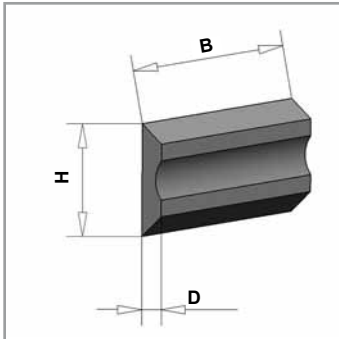

60030

APPLICATION:

HS 18% = For soft wood and hard wood

DESIGN:

Ground ready for use
TOK = can be resharpened

Packing unit 2 pcs.

Available also in HW

Width mm	Height mm	Thickness mm	DT	Order No.
50	14	2,5	◇	10041818
60	14	2,5	◇	10041819
80	14	2,5	◇	10041821
100	14	2,5	◇	10016798
110	14	2,5	◇	10041822
120	14	2,5	◇	10026751
130	14	2,5	◇	40010764
136	14	2,5	◇	10041824
140	14	2,5	◇	40002272
150	14	2,5	◇	10041827
160	14	2,5	◇	10041828
170	14	2,5	◇	40003450
180	14	2,5	◇	40015637
186	14	2,5	◇	10041829
190	14	2,5	◇	10030863
200	14	2,5	◇	10041830
210	14	2,5	◇	10031772
220	14	2,5	◇	10041831
230	14	2,5	◇	40015602
240	14	2,5	◇	10030961
250	14	2,5	◇	10041832
260	14	2,5	◇	40010788
270	14	2,5	◇	40011993
300	14	2,5	◇	10041833
310	14	2,5	◇	10031773
350	14	2,5	◇	10041834
360	14	2,5	◇	10041835
400	14	2,5	◇	10041836
410	14	2,5	◇	40010787
420	14	2,5	◇	10041837
510	14	2,5	◇	10041838
610	14	2,5	◇	10041839

S AWBLADES
H HOGGERS
C UTTER WITH BORE
S HANK TYPE CUTTERS
D RILLS
K NIVES
C LAMPING SYSTEM
DP - TOOLS
A CCESSORIES

Knives for system Tera

Quality HW, HS and HS M42

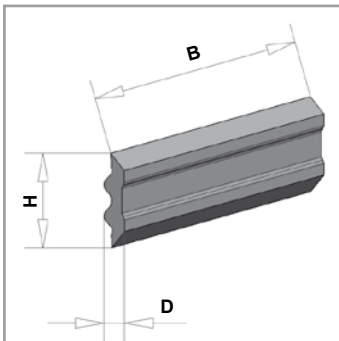

60030 / 60070

APPLICATION:

Solid carbide = For hard wood, laminated wood and panel material.

HS = For soft wood and hard wood

HS M42 = For soft wood

DESIGN:

Ground ready for use

Disposable TOK = cannot be resharpened

M42 - black oxide coated

Packing unit 2 pcs.

Width mm	Height mm	Thickness mm	DT	Order No. HW	Order No. HS	Order No. HS M42
60	10	2,3	◇	40011475	10028436	10153532
80	10	2,3	◇	40000211	10028437	10153533
100	10	2,3	◇	10017832	10028438	10153534
110	10	2,3	◇	40009221	40008485	10153535
120	10	2,3	◇	10014494	10026611	10153536
130	10	2,3	◇	10015031	10014208	10153537
150	10	2,3	◇	40000215	40000148	10153538
170	10	2,3	◇	40000216	10024019	10153539
180	10	2,3	◇	40000217	40004210	10153540
210	10	2,3	◇	10015023	10031844	10153541
230	10	2,3	◇	40000220	40004211	10153542
250	10	2,3	◇	40000221	40000187	10153543
260	10	2,3	◇	40000222	10101520	10153544
280	10	2,3	◇	10101679	40015992	10153545
300	10	2,3	◇	10015024	10021300	10153546
310	10	2,3	◇	40006757	10103105	40012737
350	10	2,3	◇	40000227	10026483	10153547
360	10	2,3	◇	40000228	40000193	10153548
400	10	2,3	◇	10015022	10022144	10153549
410	10	2,3	◇	40006756	10023233	40012738
420	10	2,3	◇	10101870	40009757	10153550
430	10	2,3	◇	10101871	10016490	10153551
450	10	2,3	◇	40000232	40000197	10153552
500	10	2,3	◇	10018542	10016946	10153553
510	10	2,3	◇	10020306	10015656	10143759
520	10	2,3	◇	10024394	10100544	10153554
530	10	2,3	◇	40011354	40002744	10153555
610	10	2,3	◇	10101953	10022151	10153556
630	10	2,3	◇	10021972	10015180	40015615
640	10	2,3	◇	10014307	10100537	10143760
710	10	2,3	◇	10110490	10025157	10153557
810	10	2,3	◇	10110491	40008077	10153558

NEW

SAWBLADES

S

HOGGERS

H

CUTTER WITH BORE

C

CUTTERS

S

DRILLS

D

KNIVES

K

LAMPING SYSTEM

C

TOOLS

DP

ACCESSORIES

A

Reversible knives for Rali hand planer

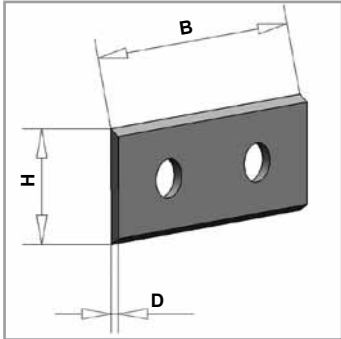

60070

APPLICATION:

HS 18 % = For soft wood and hard wood
HW = For hard wood, laminated wood and panel material.

DESIGN:

Ground ready for use
Disposable TOK = cannot be resharpened

Packing unit 10 pcs.

Width mm	Height mm	Thick-ness mm	Quality	for Rali Type	DT	Order No.
30	12	1	HS 18%	G30 cornice planer	◇	10102248
48	12	1	HS 18%	105/220	◇	10102247
48	12	1	HW	105/220	◇	40000753

Further qualities (hardness, bending strength) and dimensions available

S AWBLADES

H HOGGERS

C UTTER WITH BORE

S HANK TYPE CUTTERS

D RILLS

K NIVES

C LAMPING SYSTEM

DP - TOOLS

A CCESSORIES

HW Turn over knives 35°

APPLICATION: K05 = For hard wood, laminated wood and panel material.
K01 = For panel material and plastic material

DESIGN: Ground ready for use
Disposable TOK = cannot be resharpened

Packing unit 10 pcs.

63070

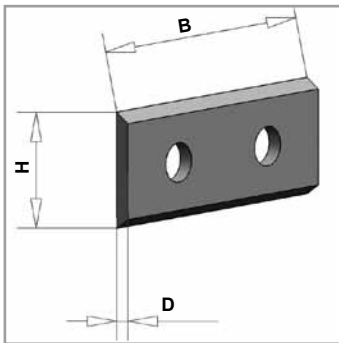

2 Cutting edges (35°)

Width mm	Height mm	Thickness mm	Order No. K05	Order No. K01
7,5	12	1,5	10009449	
7,65	12	1,5	10009477	
9,6	12	1,5	10009480	
11,6	12	1,5	10009483	
15	12	1,5	10009455	10009492
20	12	1,5	10009457	10022241
25	12	1,5	40016017	
30	12	1,5	10009464	10009500
40	12	1,5	10009466	10023095
50	12	1,5	10009474	10009503
60	12	1,5	10009476	
80	13	2,2	10009478	
100	13	2,2	10009481	
120	13	2,2	10009484	

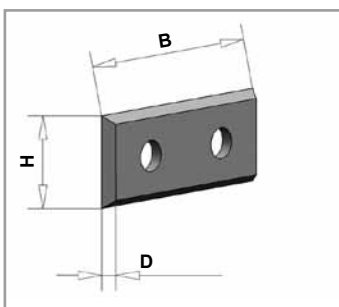

4 Cutting edges (35°)

Width mm	Height mm	Thickness mm	Order No. K05	Order No. K01
12	12	1,5	10009450	40005307
15	12	1,5	10009521	10102312
20	12	1,5	10009521	10102314
30	12	1,5	10009523	10102315
40	12	1,5	10009524	
50	12	1,5	10009525	10102316
50	12	1,7		10009526
60	12	1,5	10009527	

SAWBLADES
LOGGERS
CUTTER WITH BORE
SHANK TYPE CUTTERS
DRILLS
KNIVES
CLAMPING SYSTEM
TOOLS
ACCESSORIES

HW Turn over knives 45°

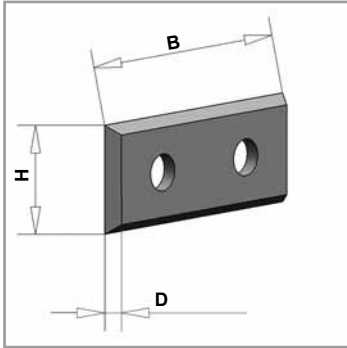

63070

APPLICATION:

K05 = For hard wood, laminated wood and panel material.

DESIGN:

K01 = For panel material and plastic material

Ground ready for use

Disposable TOK = cannot be resharpened

Packing unit (VE) 10 pcs.

2 Cutting edges (45°)

Width mm	Height mm	Thickness mm	Quality	DT	Order No.
15	12	1,5	K05	◇	10022249
20	12	1,5	K05	◇	10019782
30	12	1,5	K05	◇	10018999
40	12	1,5	K05	◇	10022250
50	12	1,5	K05	◇	10022251
60	12	1,5	K05	◇	10022252

HW wipers and spurs

Standard - Raker for grooving cutter head and adjustable grooving cutter head

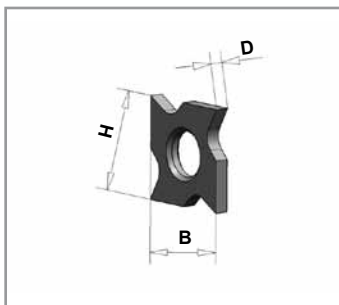

Width mm	Height mm	Thickness mm	Quality	DT	Order No.
18	18	1,95	HW	◇	10009494
18	18	2,45	HW	◇	10009495
18	18	2,95	HW	◇	10009496

HW spurs 4 Cutting edges

Width mm	Height mm	Thickness mm	Quality	Clamping system	With chip breaker groove	DT	Order No.
10,5	10,5	1,5	HW			◇	10009482
13	13	2,5	HW	Oppold		◇	10018835
13,6	13,6	2	HW		X	◇	10013923
14	14	1,2	HW	Holzher		◇	10022232
14	14	1,2	HW			◇	10009452
14	14	1,7	HW			◇	10009454
14	14	2	HW			◇	10009453
14,3	14,3	2,5	HW			◇	10009520
15	15	2	HW			◇	10009493
20	14,3	2,5	HW		X	◇	10009522
22	19	2	HW			◇	10009497*

* 3 Cutting edges

HW Turn over knives

APPLICATION: HW = For soft wood, hard wood, laminated wood and panel material.

DESIGN: Ground ready for use
Disposable TOK = cannot be resharpened

Packing unit (VE) 10 pcs.

63070

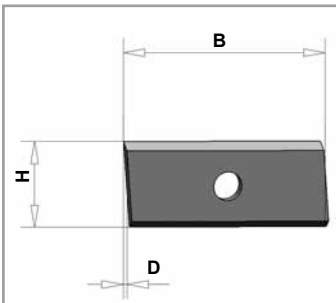

TOK with chamfer, 2 Cutting edges

Width mm	Height mm	Thickness mm	Quality	rhs/lhs	DT	Order No.
30	12	1,5	HW	lhs	◇	10022236
30	12	1,5	HW	rhs	◇	10020537
50	12	1,5	HW	lhs	◇	10022234
50	12	1,5	HW	rhs	◇	10022235

TOK with bevel, 2 Cutting edges

Width mm	Height mm	Thickness mm	Quality	rhs/lhs	DT	Order No.
30	12	1,5	HW	lhs	◇	10009462
30	12	1,5	HW	rhs	◇	10009463
50	12	1,5	HW	lhs	◇	10009472
50	12	1,5	HW	rhs	◇	10009473

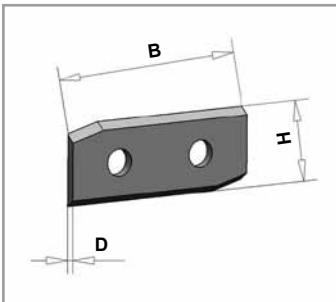

S AWBLADES

H LOGGERS

C UTTER WITH BORE

S HANK TYPE CUTTERS

D RILLS

K NIVES

C LAMPING SYSTEM

DP - TOOLS

A CCESSORIES

NEW

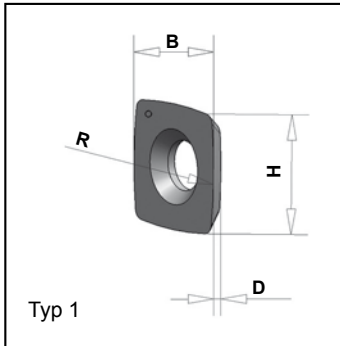

Typ 1

63070

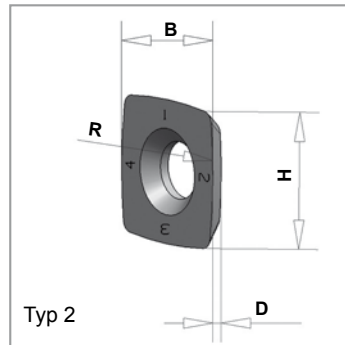

Typ 2

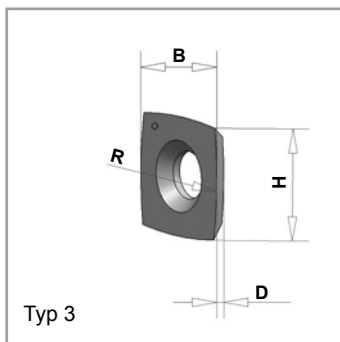

Typ 3

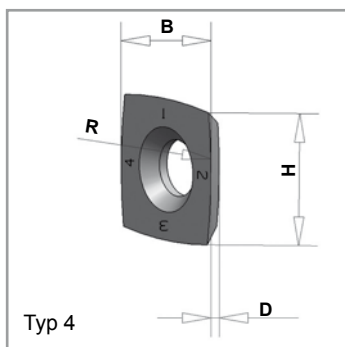

Typ 4

HW Turn over knives

With rounded edges and with pointed edges

APPLICATION:

To be applied in planer heads and joining cutter heads

DESIGN:

HW = For soft wood, hard wood, laminated wood and panel material.

Ground ready for use

Disposable TOK = cannot be resharpened

Packing unit 10 pcs.

With rounded edges

Width mm	Height mm	Thickness mm	Radius	Type	Quality	DT	Order No.
15	15	2,5	150	1	HW	◇	10029730
15	15	2,5	50	1	HW	◇	10102511
15	15	2,5	115	2	HW	◇	10149346
15	15	2,5	150	2	HW	◇	10152889

APPLICATION:

To be applied in planer heads and joining cutter heads

DESIGN:

HW = For soft wood, hard wood, laminated wood and panel material.

Ground ready for use

Disposable TOK = cannot be resharpened

Packing unit 10 pcs.

With pointed edges

Width mm	Height mm	Thickness mm	Radius	Type	Quality	DT	Order No.
15,0	15	2,5	150	3	HW	◇	10132370
15,0	15	2,5	50	3	HW	◇	10152890
15,0	15	2,5	100	3	HW	◇	10152891
15,0	15	2,5	150	4	HW	◇	10152892

HW Turn over knives For System Versofix

APPLICATION: HW = For soft wood, hard wood, laminated wood and panel material.

DESIGN: Ground ready for use
Disposable TOK = cannot be resharpened

Packing unit 10 pcs.

63070

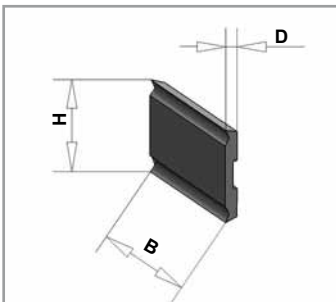

For System Versofix. With back groove, TIN coated

Width mm	Height mm	Thickness mm	Design	DT	Order No.
20	5,5	1,1	without chamfer	◇	10016255
20	10	1,5	without chamfer	◇	10102359
30	6,5	1,1	without chamfer	◇	10022273
30	10	1,5	without chamfer	◇	10021311
50	6,5	1,1	without chamfer	◇	10022274
50	10	1,5	without chamfer	◇	10021279
50	10	1,5	with bevel	◇	10017542

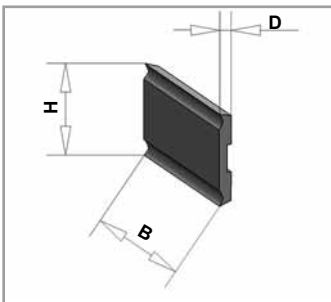

For System Versofix. With back groove, non-coated

Width mm	Height mm	Thickness mm	Design	DT	Order No.
20	5,5	1,1	without chamfer	◇	10102441
20	10	1,5	without chamfer	◇	10102446
30	6,5	1,1	without chamfer	◇	10102443
30	10	1,5	without chamfer	◇	10100711
50	6,5	1,1	without chamfer	◇	10102444
50	10	1,5	without chamfer	◇	40000676
50	10	1,5	with bevel	◇	10102447

S
AWBLADES

H
OGGERS

C
UTTER WITH BORE

S
HANK TYPE CUTTERS

D
RILLS

K
NIVES

C
LAMPING SYSTEM

DP - TOOLS

A
CCESSORIES

HW Turn over knives

System Oppold, Hundegger, Weinmann, Weinig

APPLICATION:

HW = For soft wood, hard wood, laminated wood and panel material.

DESIGN:

Ground ready for use
Disposable TOK = cannot be resharpened

Packing unit 10 pcs.

63070

For System Oppold

Width mm	Height mm	Thickness mm	Quality	DT	Order No.
30	12	1,5	HW	◇	10009547
44,5	15	1,5	HW	◇	10102357

HW edge knives, System Oppold

NEW

Width mm	Height mm	Thickness mm	Edge	Quality	Order No.
22	16	5	45°	HW	10109412
22	16	5	R 1,5	HW	10022276
22	16	5	R 2	HW	10022277
22	16	5	R 2,5	HW	10022278
22	16	5	R 3	HW	10107583

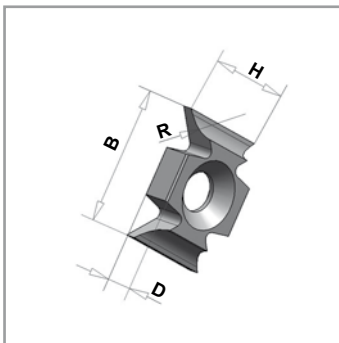

TOK. System Hundegger

Width mm	Height mm	Thickness mm	Quality	Order No.
21	21	5,5	HW	10015491

TOK. System Hundegger/Weinmann/Weinig

Width mm	Height mm	Thickness mm	Quality	Order No.
17	17	2	HW	10014012
19	19	2	HW	10017958

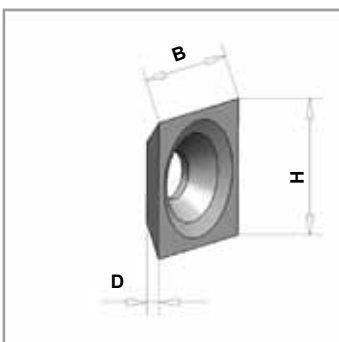

HW Edge knives

NEW

APPLICATION:

To be applied in window tools and profile tools
For soft wood, hard wood, laminated wood and
panel material

DESIGN:

Ground ready for use
Disposable TOK = cannot be resharpened

Packing unit 1 pcs.

63070

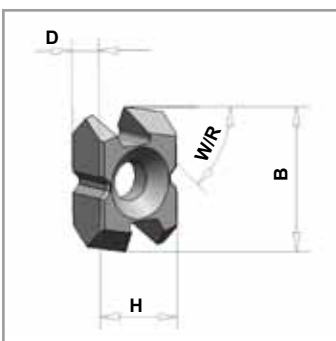
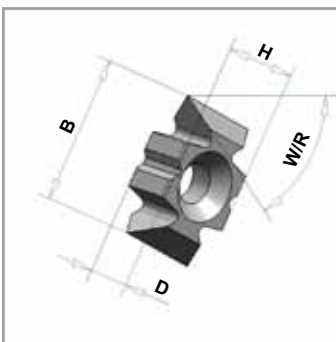
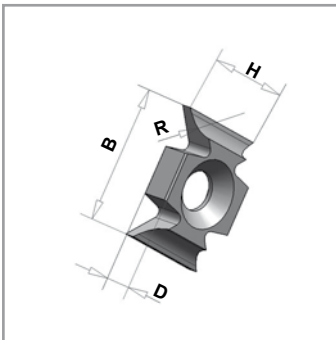

Edge knives for MEC feed

Width mm	Height mm	Thickness mm	Radius	Quality	Order No.
16	22	5	45°	HW	10109412
16	22	5	1,5	HW	10022276
16	22	5	2,0	HW	10022277
16	22	5	2,5	HW	10022278
16	22	5	3,0	HW	10107583
16	22	5	4,0	HW	40003967
16	22	6	5,0	HW	10157339

Edge knives for System Leitz - MEC feed

Width mm	Height mm	Thickness mm	Radius	Quality	Order No.
15.0	20.0	8.0	11/0 - 45°	HW	10116013
15.0	22.3	9.0	12/0 R3	HW	10107377
15.0	20.0	9.0	12/1 R3	HW	10152671
15.0	20.0	7.3	12/3 R2	HW	10119426
15.0	18.3	7.3	12/3 R2F	HW	10152672
15.0	20.0	7.0	12/4 R1,5	HW	10152673
15.0	22.3	10.0	12/5 R3F	HW	10152674
15.0	22.3	7.3	13/0 (R1) N=5	HW	10152675
15.0	22.3	9.0	13/1 (R1) N=7	HW	10152676
15.0	22.3	7.3	16/0	HW	10106249

Edge knives for System Leitz - MAN feed

Width mm	Height mm	Thickness mm	Radius	Quality	Order No.
15.0	23.0	8.0	21/0-45°	HW	40016091
15.0	23.0	9.0	22/0 R3	HW	40012181
15.0	23.0	7.3	22/3 R2	HW	40008690
15.0	23.0	7.0	22/4 R1,5	HW	10152677
15.0	23.0	9.0	22/5 R3F	HW	10152678
15.0	23.0	9.0	22/1 R3	HW	10152679
15.0	25.7	7.3	24/0 R5	HW	10152680
15.0	25.7	7.3	24/1 R5	HW	10109612

S AWBLADES

H LOGGERS

C UTTER WITH BORE

S HANK TYPE CUTTERS

D RILLS

K NIVES

C LAMPING SYSTEM

C

DP - TOOLS

A CCESSORIES

HW Mini-Turn over knives

APPLICATION:

HW = For soft wood, hard wood, laminated wood and panel material.

DESIGN:

Ground ready for use
Disposable TOK = cannot be resharpened

Packing unit 10 pcs.

63070

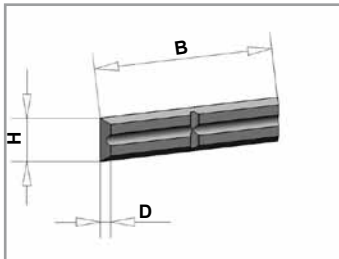

Mini-TOK with back groove and cross groove, 4 Cutting edges

Width mm	Height mm	Thickness mm	Quality	Order No.
20	4,1	1,1	HW	10006964
20	5,5	1,1	HW	10006965
25	5,5	1,1	HW	10006966
30	5,5	1,1	HW	10006967
40	5,5	1,1	HW	10009507
50	5,5	1,1	HW	10006968

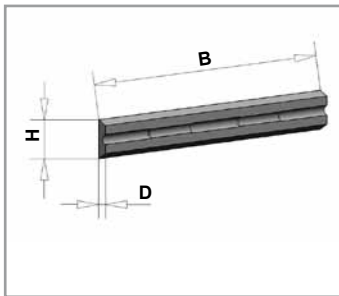

Mini-TOK with back groove for portable planers, 2 Cutting edges

Width mm	Height mm	Thickness mm	Quality	Order No.
56	5,5	1,1	HW	10009513
60	5,5	1,1	HW	10009514
75,5	5,5	1,1	HW	10009515
80,5	5,9	1,1	HW	10009516
80,5	5,5	1,1	HW	10102061
82	5,5	1,1	HW	10009517
102	5,5	1,1	HW	10022256

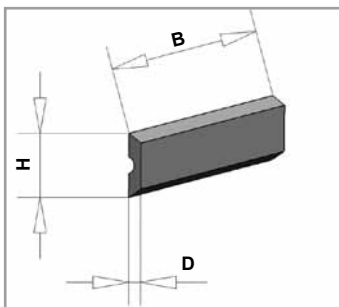

Mini-TOK with face groove, 2 Cutting edges

Width mm	Height mm	Thickness mm	Quality	Order No.
7,7	8	1,5	HW	10022262
9,7	8	1,5	HW	10101123
11,7	8	1,5	HW	10013991
14,7	8	1,5	HW	10013999
19,7	8	1,5	HW	10020269
24,7	8	1,5	HW	10022266
30	8	1,5	HW	10014024
35	8	1,5	HW	10022267
40	8	1,5	HW	10026542
50	8	1,5	HW	10022268
60	8	1,5	HW	10021809
80	8	1,5	HW	10022269
100	8	1,5	HW	10022270
120	8	1,5	HW	10022271

HW Mini-Turn over knives

APPLICATION: HW = For soft wood, hard wood, laminated wood and panel material.

DESIGN: Ground ready for use
Disposable TOK = cannot be resharpened

Packing unit 10 pcs.

63070

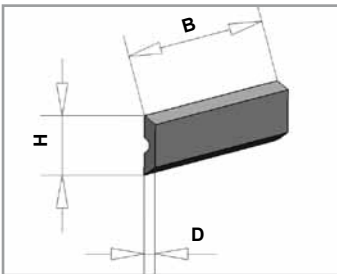

Mini-TOK with face groove, 2 Cutting edges

Width mm	Height mm	Thickness mm	Quality	Order No.
12	5,5	1,1	HW	10009485
20	5,5	1,1	HW	10009458
30	5,5	1,1	HW	10009501
40	5,5	1,1	HW	10009510
50	5,5	1,1	HW	10009511

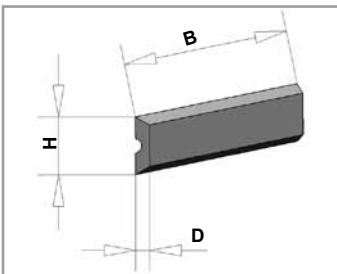

Mini-TOK with face groove, 4 Cutting edges

Width mm	Height mm	Thickness mm	Quality	Order No.
20	5,5	1,1	HW	10009499
30	5,5	1,1	HW	10009465
40	5,5	1,1	HW	10009488
50	5,5	1,1	HW	10009489

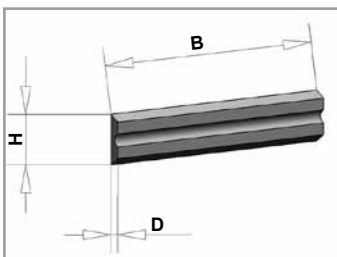

Mini-TOK with back groove, 2 Cutting edges

Width mm	Height mm	Thickness mm	Quality	Order No.
12	5,5	1,1	HW	10009451
20	5,5	1,1	HW	10009505
30	5,5	1,1	HW	10009506
40	5,5	1,1	HW	10009502
50	5,5	1,1	HW	10009512

Mini-TOK with back groove, 4 Cutting edges

Width mm	Height mm	Thickness mm	Quality	Order No.
20	5,5	1,1	HW	40002439
30	5,5	1,1	HW	10009509
40	5,5	1,1	HW	40000665
50	5,5	1,1	HW	40000662

HW radius turn over knives

APPLICATION:

For TOK rounding cutter heads

DESIGN:

Ground ready for use
Disposable TOK = cannot be resharpened

Packing unit 10 pcs.

62010

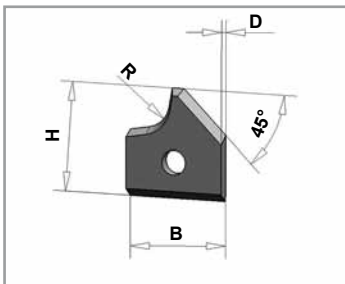

Fig. Bevel - TOK left



Abb.: Bevel - TOK right



Bevel TOK

Width mm	Height mm	Thick-ness mm	Radius mm	Quality	R/L	DT	Order No.
16	17,5	2	2/45°	HW	lhs	◇	10105228
16	17,5	2	2/45°	HW	rhs	◇	10105235
16	17,5	2	3/45°	HW	lhs	◇	10041321
16	17,5	2	3/45°	HW	rhs	◇	10041322
16	17,5	2	4/45°	HW	lhs	◇	10105229
16	17,5	2	4/45°	HW	rhs	◇	10105236
16	17,5	2	5/45°	HW	lhs	◇	10041352
16	17,5	2	5/45°	HW	rhs	◇	10041353
16	17,5	2	6/45°	HW	lhs	◇	40009325
16	17,5	2	6/45°	HW	rhs	◇	40009324
24	20	2	6/45°	HW	lhs	◇	10105230
24	20	2	6/45°	HW	rhs	◇	10105238
24	20	2	7/45°	HW	lhs	◇	10105231
24	20	2	7/45°	HW	rhs	◇	10105239
24	20	2	8/45°	HW	lhs	◇	10105232
24	20	2	8/45°	HW	rhs	◇	10105240
24	20	2	9/45°	HW	lhs	◇	10105233
24	20	2	9/45°	HW	rhs	◇	10105241
24	20	2	10/45°	HW	lhs	◇	10105234
24	20	2	10/45°	HW	rhs	◇	10105242

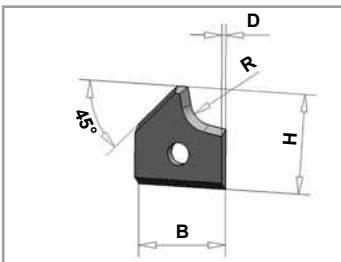
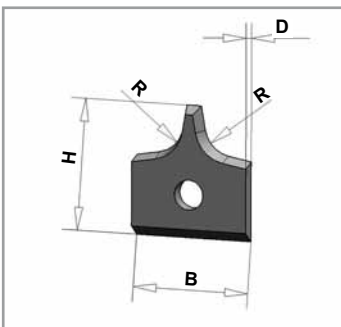
Double radius TOK

Width mm	Height mm	Thickness mm	Radius mm	Quality	DT	Order No.
16	17,5	2	2	HW	◇	10009564
16	17,5	2	3	HW	◇	10009565
16	17,5	2	4	HW	◇	10009566
16	17,5	2	5	HW	◇	10042291
24	20	2	6	HW	◇	10010672
24	20	2	7	HW	◇	10041052
24	20	2	8	HW	◇	10010674
24	20	2	9	HW	◇	10010675
24	20	2	10	HW	◇	10010676

HW rounding scraper

APPLICATION: To be applied on edge banding machines

DESIGN: Ground ready for use
Disposable TOK = cannot be resharpened

Packing unit 1 pcs.

62010

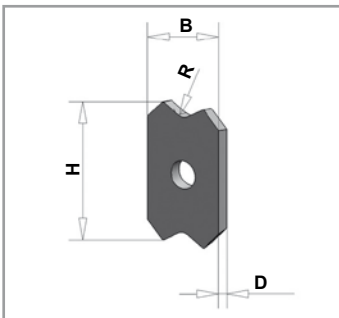

HW rounding scraper - Standard

Width mm	Height mm	Thick-ness mm	Radius/bevel mm	DT	Quality	Order No.
12	20	2	45°	◇	HW	10010909
12	20	2	0,8	◇	HW	10010889
12	20	2	1	◇	HW	10010890
12	20	2	1,5	◇	HW	10041220
12	20	2	2	◇	HW	10040875
12	20	2	2,5	◇	HW	10010893
12	20	2	3	◇	HW	10010894
12	20	2	3,5	◇	HW	10010895
12	20	2	4	◇	HW	10010896
12	20	2	4,5	◇	HW	10010897
12	20	2	5	◇	HW	10010898

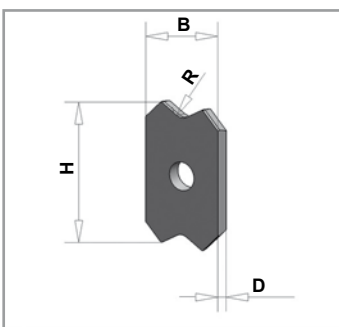

NEW

HW rounding scraper - Anti stress whitening

Width mm	Height mm	Thick-ness mm	Radius/bevel mm	DT	Quality	Order No.
12	20	2	1,5	◇	HW	10041420
12	20	2	2	◇	HW	10105119
12	20	2	3	◇	HW	10041098

S AWBLADES
H OGGER
C UTTER WITH BORE
S HANK TYPE CUTTERS
D RILLS
K NIVES
C LAMPING SYSTEM
DP - TOOLS
A CCESSORIES

HW radius and bevel turn over knives

APPLICATION:

Applied in TOK rounding cutters

DESIGN:

Ground ready for use

Disposable TOK = cannot be resharpened

Packing unit 10 pcs.

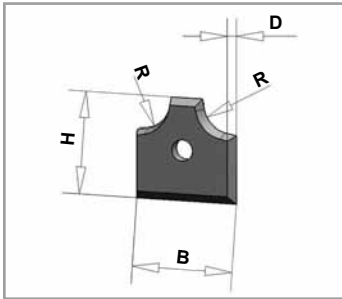

62010

Width mm	Height mm	Thick-ness mm	Radius/ bevel mm	Quality	DT	Order No.
12	12	1,5	2	HW	◇	10027095
12	12	1,5	3	HW	◇	40010959
12	12	1,5	4	HW	◇	10111852
12	12	1,5	45°	HW	◇	10111904
12	13	2	2	HW	◇	10108816
12	13	2	2,5	HW	◇	10107782
12	13	2	3	HW	◇	10019565

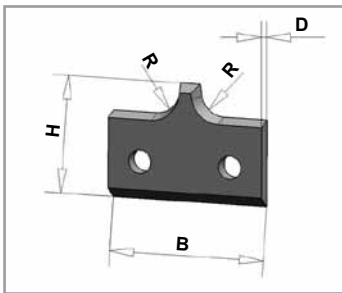

Width mm	Height mm	Thick-ness mm	Radius mm	Quality	DT	Order No.
30	17	2	5	HW	◇	10027272
30	17	2	6	HW	◇	10111856
30	17	2	7	HW	◇	10111857
30	17	2	8	HW	◇	40003508

HW radius turn over knives

APPLICATION:

Applied in TOK rounding cutters for edge banding machines

DESIGN:

Ground ready for use

Disposable TOK = cannot be resharpened

Packing unit 10 pcs.

62010

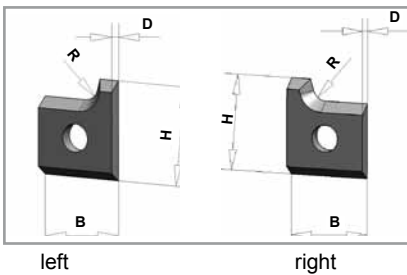

Width mm	Height mm	Thick-ness mm	Radius mm	Quality	rhs/lhs	DT	Order No.
12	14,5	2	2	HW	lhs	◇	10111708
12	14,5	2	2	HW	rhs	◇	10100362
12	14,5	2	2,5	HW	lhs	◇	10016519
12	14,5	2	2,5	HW	rhs	◇	10016520
12	14,5	2	3	HW	lhs	◇	10106422
12	14,5	2	3	HW	rhs	◇	10106421

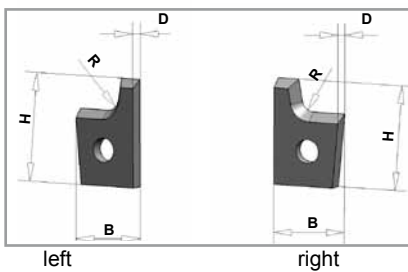

Width mm	Height mm	Thick-ness mm	Radius mm	Quality	rhs/lhs	DT	Order No.
12	18	2	2	HW	lhs	◇	10014840
12	18	2	2	HW	rhs	◇	10014841
12	18	2	3	HW	lhs	◇	10023933
12	18	2	3	HW	rhs	◇	10023932

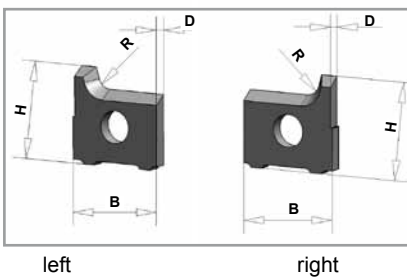

Width mm	Height mm	Thick-ness mm	Radius mm	Quality	rhs/lhs	DT	Order No.
15	14,5	2	2	HW	lhs	◇	10042286
15	14,5	2	2	HW	rhs	◇	10042285
15	14,5	2	2,5	HW	lhs	◇	40007470
15	14,5	2	2,5	HW	rhs	◇	40007471
15	14,5	2	3	HW	lhs	◇	10016132
15	14,5	2	3	HW	rhs	◇	10016131

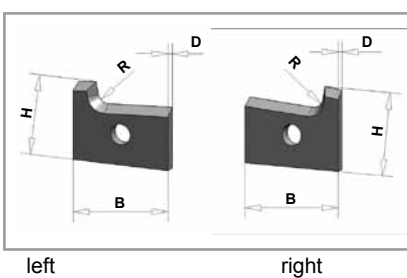

Width mm	Height mm	Thick-ness mm	Radius mm	Quality	rhs/lhs	DT	Order No.
19,6	15,2	2	2	HW	lhs	◇	10101053
19,6	15,2	2	2	HW	rhs	◇	10101054
19,6	15,2	2	3	HW	lhs	◇	10042212
19,6	15,2	2	3	HW	rhs	◇	10042213

HW radius turn over knives Double radius turn over knives

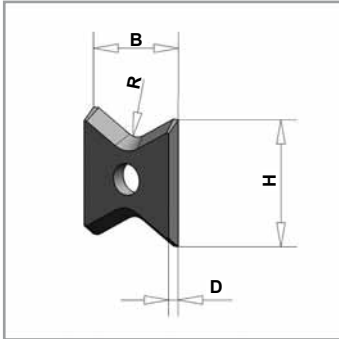

62010

APPLICATION:

For TOK rounding cutter heads

DESIGN:

Ground ready for use
Disposable TOK = cannot be resharpened

Packing unit 10 pcs.

Width mm	Height mm	Thick-ness mm	Radius/bevel mm	Quality	DT	Order No.
13	16	2	2/5°	HW	◇	10041187
13	16	2	2/15°	HW	◇	10111821
13	16	2	3/5°	HW	◇	10009550
13	16	2	3/15°	HW	◇	10111824
13	16	2	4/5°	HW	◇	10009551
13	16	2	4/15°	HW	◇	10111825

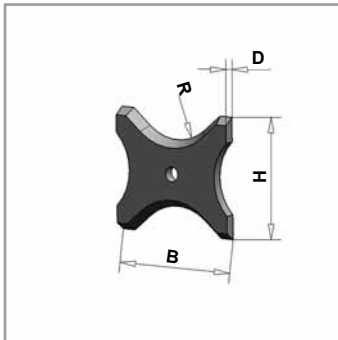

Width mm	Height mm	Thick-ness mm	Radius mm	Quality	DT	Order No.
20	21	2	5	HW	◇	10009552
20	21	2	6	HW	◇	10009553
20	21	2	7	HW	◇	10009554
20	21	2	8	HW	◇	10009555
26	24	2	9	HW	◇	10009556
26	24	2	10	HW	◇	10009557
26	24	2	11	HW	◇	10009558
26	24	2	12	HW	◇	10009559

Blancs with back tothing

Super Pac

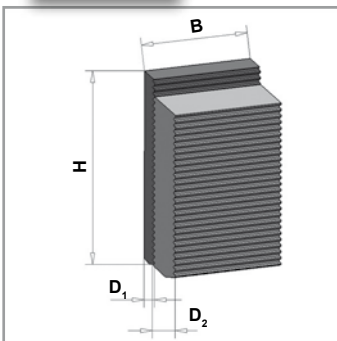
NEW

62010
APPLICATION:

For profile cutter heads with 90° back tothing.
 Knife thickness 10 mm.
 For hard wood, laminated wood and panel material.
 H=38 mm: planing
 H=50 mm PD max 12 mm.
 H=60 mm PD max 23 mm

DESIGN:

HW knife with back tothing to be applied with support plate,
 unprofiled
 Packing unit 1 pcs.

Width mm	Height mm	Thick-ness mm	DT	Order No. knives	Height mm	Thick-ness mm	DT	Order No. support plate
40	38	3,2	◇	10141408	35	7,1	◇	33014874
50	38	3,2	◇	33013989	35	7,1	◇	33013990
60	38	3,2	◇	10130824	35	7,1	◇	10130826
80	38	3,2	◇	10139613	35	7,1	◇	33014322
100	38	3,2	◇	10121199	35	7,1	◇	10116065
120	38	3,2	◇	10153039	35	7,1	◇	10153057
130	38	3,2	◇	10153040	35	7,1	◇	10116064
150	38	3,2	◇	10153041	35	7,1	◇	33014175
170	38	3,2	◇	10141407	35	7,1	◇	33014177
180	38	3,2	◇	10153042	35	7,1	◇	10153059
200	38	3,2	◇	10153043	35	7,1	◇	10153060
210	38	3,2	◇	33015151	35	7,1	◇	10153061
230	38	3,2	◇	10153044	35	7,1	◇	10153062
310	38	3,2	◇	10153045	35	7,1	◇	10153063
330	38	3,2	◇	10153046	35	7,1	◇	10153064
40	50	3,2	◇	10116661	47	7,1	◇	33014118
50	50	3,2	◇	33014001?	47	7,1	◇	33014002
60	50	3,2	◇	33014125	47	7,1	◇	33014126
80	50	3,2	◇	10153047	47	7,1	◇	33014278
100	50	3,2	◇	10121421	47	7,1	◇	10121422
120	50	3,2	◇	10153048	47	7,1	◇	10153065
130	50	3,2	◇	10153049	47	7,1	◇	10153066
150	50	3,2	◇	10153050	47	7,1	◇	33015129
170	50	3,2	◇	33013980	47	7,1	◇	33013979
180	50	3,2	◇	10153051	47	7,1	◇	10153067
200	50	3,2	◇	10153052	47	7,1	◇	10153068
210	50	3,2	◇	10153053	47	7,1	◇	10153069
230	50	3,2	◇	10153054	47	7,1	◇	10153070
310	50	3,2	◇	10153055	47	7,1	◇	10153071
330	50	3,2	◇	10153056	47	7,1	◇	10153072

Super Pack HW knives with support plate. Total thickness 10 mm

Blancs with back tothing Super Pac

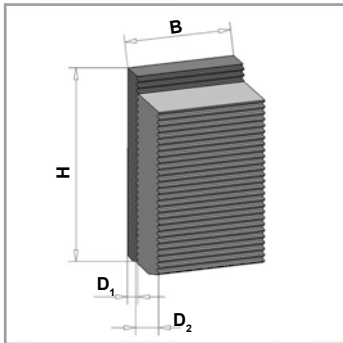
NEW

62010
APPLICATION:

For profile cutter heads with 90° back tothing.
 Knife thickness 10 mm
 For hard wood, laminated wood and panel materia.
 H= 38 mm: Zum Hobeln
 H= 50 mm PT max 12 mm
 H = 60 mm PT max 23 mm

DESIGN:

HW knife with back tothing to be applied with support plate,
 unprofiled
 Packing unit 1 pcs.

Width mm	Height mm	Thick-ness mm	DT	Order No. knives	Height mm	Thick-ness mm	DT	Order No. support plate
40	60	3,2	◇	10121746	57	7,1	◇	33012975
50	60	3,2	◇	10121745	57	7,1	◇	10121747
60	60	3,2	◇	10116945	57	7,1	◇	33012853
80	60	3,2	◇	33012875	57	7,1	◇	33012877
100	60	3,2	◇	33011973	57	7,1	◇	33014224
120	60	3,2	◇	10141656	57	7,1	◇	10141657
130	60	3,2	◇	10142454	57	7,1	◇	33012304
150	60	3,2	◇	10152834	57	7,1	◇	33014225
170	60	3,2	◇	10152835	57	7,1	◇	33012852
180	60	3,2	◇	10152836	57	7,1	◇	10152843
200	60	3,2	◇	10152837	57	7,1	◇	10152845
210	60	3,2	◇	10152838	57	7,1	◇	10152846
230	60	3,2	◇	10152839	57	7,1	◇	10152847
310	60	3,2	◇	10152841	57	7,1	◇	10152849
330	60	3,2	◇	10152842	57	7,1	◇	10152851

Super Pack HW knives with support plate. Total thickness 10 mm
Allocation: knives - Cutter head

D Cutter head mm	Height 40	Height 50	Height 60	Height 70
122	142	162	182	202
135	154	174	194	214
145	164	184	204	224
150	169	189	209	229
165	184	204	224	244
170	189	209	229	249
190	209	229	249	269

HS Blancs with back tothing

Thickness 5 mm

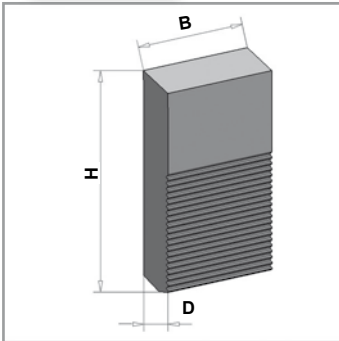
NEW**62030****APPLICATION:**

For profile cutter heads with 90° back tothing.
 Knife thickness 5 mm
 For hard wood, laminated wood and panel material.
 H= 27 mm: for planing
 H= 38 mm: for planing
 H= 50 mm PT max 8 mm

DESIGN:

HS knives, unprofiled

Packing unit 1 pcs.

Width mm	Height mm	Thick-ness mm	DT	Order No.	Width mm	Height mm	Thick-ness mm	DT	Order No.
20	27	5,0	◇	10153165	20	38	5,0	◇	10153189
30	27	5,0	◇	10153167	30	38	5,0	◇	10153190
40	27	5,0	◇	10153168	40	38	5,0	◇	10153191
50	27	5,0	◇	10153169	50	38	5,0	◇	10153192
60	27	5,0	◇	10153171	60	38	5,0	◇	10153193
70	27	5,0	◇	10153172	70	38	5,0	◇	10153194
80	27	5,0	◇	10153173	80	38	5,0	◇	10153197
90	27	5,0	◇	10153174	90	38	5,0	◇	10153198
100	27	5,0	◇	10153175	100	38	5,0	◇	10153199
110	27	5,0	◇	10153176	110	38	5,0	◇	10153200
120	27	5,0	◇	10153177	120	38	5,0	◇	10153201
130	27	5,0	◇	10153178	130	38	5,0	◇	10153202
150	27	5,0	◇	10153180	150	38	5,0	◇	10153203
170	27	5,0	◇	10153181	170	38	5,0	◇	10153204
180	27	5,0	◇	10153182	180	38	5,0	◇	10153205
190	27	5,0	◇	10153183	190	38	5,0	◇	10153206
210	27	5,0	◇	10153184	210	38	5,0	◇	10153207
230	27	5,0	◇	10153185	230	38	5,0	◇	10153208
240	27	5,0	◇	10153186	240	38	5,0	◇	10153209
650	27	5,0	◇	10153187	650	38	5,0	◇	10153210

SAWBLADES

HOGGERS

CUTTER WITH BORE

SHANK TYPE CUTTERS

DRILLS

KNIVES

LAMPING SYSTEM

DP - TOOLS

ACCESSORIES

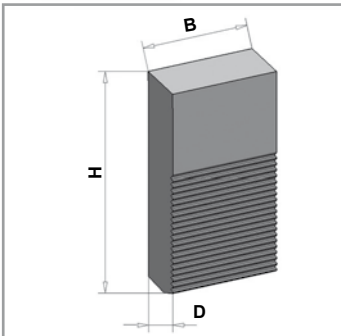
NEW**62030****HS Blancs with back tooling**

Thickness 5 mm

APPLICATION:

For profile cutter heads with 90° back tooling.
 Knife thickness 5 mm
 For hard wood, laminated wood and panel material.
 H= 27 mm: for planing
 H= 38 mm: for planing
 H= 50 mm DP max 8 mm

DESIGN:

HS knives, unprofiled
 Packing unit (VE) 1 pcs.

Width mm	Height mm	Thick-ness mm	DT	Order No.	Width mm	Height mm	Thick-ness mm	DT	Order No.
20	45	5,0	◇	10153221	20	50	5,0	◇	10153242
30	45	5,0	◇	10153222	30	50	5,0	◇	10153243
40	45	5,0	◇	10153224	40	50	5,0	◇	10153244
50	45	5,0	◇	10153225	50	50	5,0	◇	10153245
60	45	5,0	◇	10153226	60	50	5,0	◇	10150676
70	45	5,0	◇	10153228	70	50	5,0	◇	10153251
80	45	5,0	◇	10153229	80	50	5,0	◇	10153252
90	45	5,0	◇	10153230	90	50	5,0	◇	10153253
100	45	5,0	◇	10153231	100	50	5,0	◇	10153255
110	45	5,0	◇	10153232	110	50	5,0	◇	10153256
120	45	5,0	◇	10153233	120	50	5,0	◇	10153257
130	45	5,0	◇	10153234	130	50	5,0	◇	10153258
150	45	5,0	◇	10153235	150	50	5,0	◇	10153259
170	45	5,0	◇	10153236	170	50	5,0	◇	10153260
180	45	5,0	◇	10153237	180	50	5,0	◇	10153261
190	45	5,0	◇	10153238	190	50	5,0	◇	10153262
210	45	5,0	◇	10153239	210	50	5,0	◇	10153263
230	45	5,0	◇	10153240	230	50	5,0	◇	10153264
240	45	5,0	◇	10153241	240	50	5,0	◇	10153265
650	45	5,0	◇	33015329	650	50	5,0	◇	10153267

Allocation: knives - cutterhead

D Kopf mm	Height 40	Height 50	Height 60	Height 70
122	142	162	182	202
135	154	174	194	214
145	164	184	204	224
150	169	189	209	229
165	184	204	224	244
170	189	209	229	249
190	209	229	249	269

Blancs with back tothing

HS, thickness 8 mm

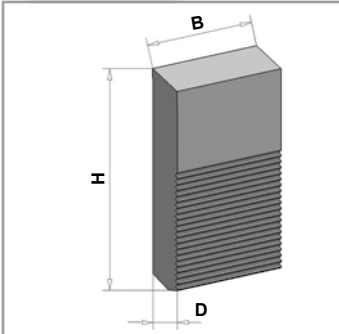
NEW**62030****APPLICATION:**

For profile cutter heads with 90° back tothing.
 Knife thickness 8 mm
 For soft wood and hard wood
 H=40mm: for planing
 H=50 mm: PT max 12 mm
 H=60 mm: PT max 18 mm
 H=70 mm: PT max 30 mm

DESIGN:

Unprofiled blanc to be applied in profile cutter heads with 90° back tothing. Please observe the cutter head's circle of rotation when the knives are inserted

Width mm	Height mm	Thickness mm	Quality	DT	Order No.
40	40	8	HS	◇	10152894
50	40	8	HS	◇	10152901
60	40	8	HS	◇	10152902
70	40	8	HS	◇	10152903
80	40	8	HS	◇	33015070
90	40	8	HS	◇	10152904
100	40	8	HS	◇	10152905
110	40	8	HS	◇	10152906
120	40	8	HS	◇	10152907
130	40	8	HS	◇	10152908
150	40	8	HS	◇	10152910
170	40	8	HS	◇	10152911
180	40	8	HS	◇	10152912
200	40	8	HS	◇	40015640
210	40	8	HS	◇	10152913
230	40	8	HS	◇	10152914
260	40	8	HS	◇	10152915
650	40	8	HS	◇	10152916

Allocation: knives - cutterhead

D Kopf mm	Height 40	Height 50	Height 60	Height 70
122	142	162	182	202
135	154	174	194	214
145	164	184	204	224
150	169	189	209	229
165	184	204	224	244
170	189	209	229	249
190	209	229	249	269

Blancs with back tothing

HS , thickness 8 mm

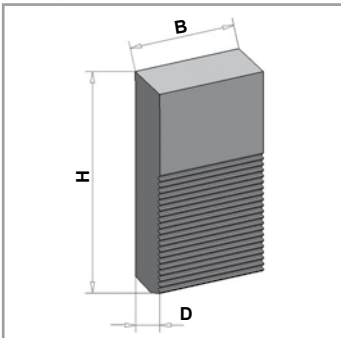
NEW**62030****APPLICATION:**

For profile cutter heads with 90° back tothing.
 Knife thickness 8 mm
 For soft wood and hard wood
 H=40mm: for planing
 H=50 mm: PT max 12 mm
 H=60 mm: PT max 18 mm
 H=70 mm: PT max 30 mm

DESIGN:

Unprofiled blanc to be applied in profile cutter heads with 90° back tothing. Please observe the cutter head's circle of rotation when the knives are inserted.

Width mm	Height mm	Thickness mm	Quality	DT	Order No.
40	50	8	HS	◇	10152917
50	50	8	HS	◇	40001590
60	50	8	HS	◇	40001589
70	50	8	HS	◇	10144742
80	50	8	HS	◇	40001588
90	50	8	HS	◇	10152918
100	50	8	HS	◇	10152919
110	50	8	HS	◇	10152920
120	50	8	HS	◇	10101128
130	50	8	HS	◇	40005616
150	50	8	HS	◇	40007038
170	50	8	HS	◇	10152921
180	50	8	HS	◇	10152922
200	50	8	HS	◇	10152923
210	50	8	HS	◇	10152924
230	50	8	HS	◇	10134776
260	50	8	HS	◇	10152925
650	50	8	HS	◇	10119754

Allocation: knives - Cutter head

D Cutter head mm	Height 40	Height 50	Height 60	Height 70
122	142	162	182	202
135	154	174	194	214
145	164	184	204	224
150	169	189	209	229
165	184	204	224	244
170	189	209	229	249
190	209	229	249	269

Blancs with back tothing

HS, thickness 8 mm

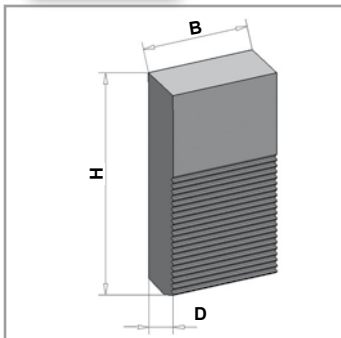
NEW**62030****APPLICATION:**

For profile cutter heads with 90° back tothing.

Knife thickness 8 mm

For soft wood and hard wood

H=50 mm: PD max 12 mm

H=60 mm: PD max 18 mm

H=70 mm: PD max 30 mm

DESIGN:

Unprofiled blanc to be applied in profile cutter heads with 90° back tothing. Please observe the cutter head's circle of rotation when the knives are inserted.

Width mm	Height mm	Thickness mm	Quality	DT	Order No.
40	60	8	HS	◇	40001597
50	60	8	HS	◇	10152996
60	60	8	HS	◇	10025040
70	60	8	HS	◇	10153004
80	60	8	HS	◇	10153005
90	60	8	HS	◇	10153008
100	60	8	HS	◇	10153009
110	60	8	HS	◇	10153010
120	60	8	HS	◇	10153011
130	60	8	HS	◇	10153012
150	60	8	HS	◇	10133570
170	60	8	HS	◇	10153013
180	60	8	HS	◇	10105248
200	60	8	HS	◇	10153014
210	60	8	HS	◇	10153015
230	60	8	HS	◇	10105250
260	60	8	HS	◇	10153016
650	60	8	HS	◇	10119755

Allocation: knives - Cutter head

D Cutter head mm	Height 40	Height 50	Height 60	Height 70
122	142	162	182	202
135	154	174	194	214
145	164	184	204	224
150	169	189	209	229
165	184	204	224	244
170	189	209	229	249
190	209	229	249	269

Blancs with back tooling HS, thickness 8 mm

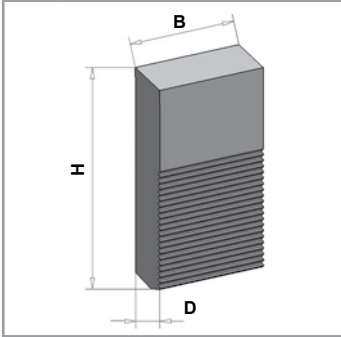
NEW**62030****APPLICATION:**

For profile cutter heads with 90° back tooling.
Knife thickness 8 mm
For soft wood and hard
H=50 mm: PD max 12 mm
H=60 mm PD max 18 mm
H=70 mm PD max 30 mm

DESIGN:

Unprofiled blank to be applied in profile cutter heads with 90° back tooling. Please observe the cutter head's circle of rotation when the knives are inserted.

Width mm	Height mm	Thickness mm	Quality	DT	Order No.
40	70	8	HS	◇	10153017
50	70	8	HS	◇	40001602
60	70	8	HS	◇	10101674
70	70	8	HS	◇	10153020
80	70	8	HS	◇	10153021
90	70	8	HS	◇	10153022
100	70	8	HS	◇	10153023
110	70	8	HS	◇	10153024
120	70	8	HS	◇	10153025
130	70	8	HS	◇	10153026
150	70	8	HS	◇	10153027
170	70	8	HS	◇	10145509
180	70	8	HS	◇	10153028
200	70	8	HS	◇	10153030
210	70	8	HS	◇	10153031
230	70	8	HS	◇	10153032
260	70	8	HS	◇	10153033
650	70	8	HS	◇	10145508

Allocation: knives - Cutter head

D Cutter head mm	Height 40	Height 50	Height 60	Height 70
122	142	162	182	202
135	154	174	194	214
145	164	184	204	224
150	169	189	209	229
165	184	204	224	244
170	189	209	229	249
190	209	229	249	269